

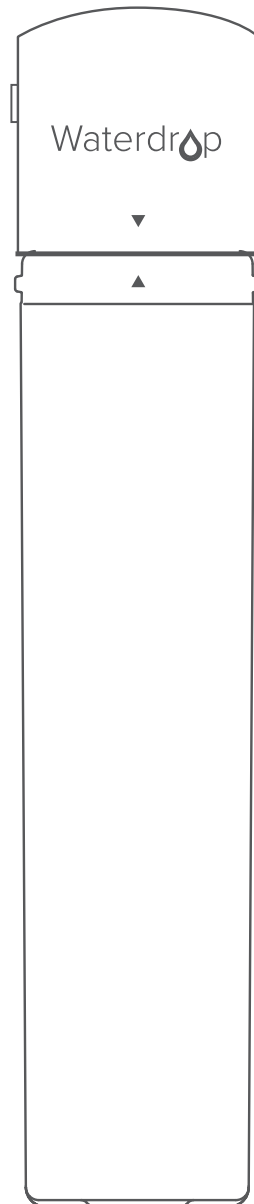

Direct Connect Undersink Water Filtration System

Model: WD-UA system



- Installation of the filter system
- Installazione del sistema di filtrazione
- Installation du système de filtration
- Instalación del sistema de filtrado
- Einbau des Filtersystems

Parts List

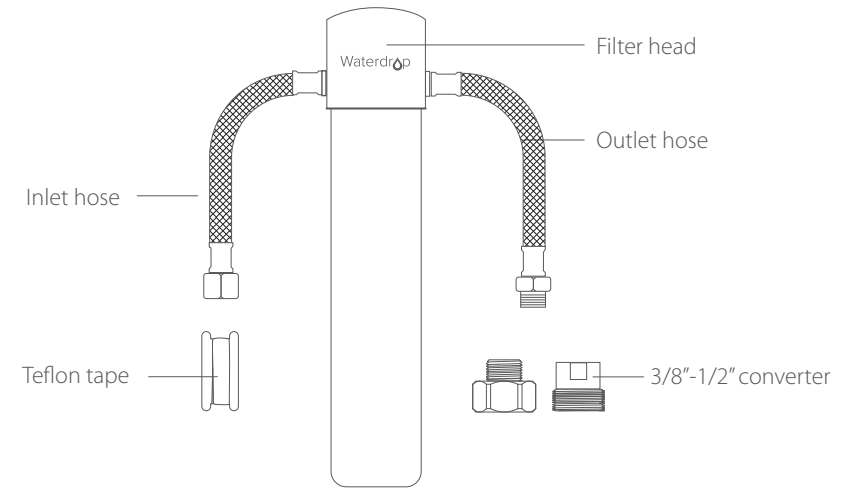

Specifications

Operating temperature	2-38°C/35-100°F
Working pressure	10-100 psi (0.7-6.8 bar)
Flow rate	0.75 gpm (2.83 lpm)
Filter capacity	WD-RF10/WD-RF10-UF/MZ/AK: up to 11,000 gallons
	WD-RF15/WD-RF15-UF/MZ/AK: up to 19,000 gallons
	WD-RF17/WD-RF17-UF/MZ/AK: up to 24,000 gallons
Feed water requirement	Municipal tap water

Note:

1. If using well water as the source, please make sure the feed water has been through a pre-filtration system, otherwise, large particles in well water will clog the filter easily and shorten filter life.
2. The above form lists model numbers of only black filters. Please note that the white filter is different from the black filter only in color. They have the same filter material and filtration capacity.
3. Actual filter life varies according to local water quality.

Precautions

- Do not use it with water that's microbiologically unsafe or of unknown quality without adequate disinfection.
- For use only with cold water.
- Do not freeze the filter, as this can cause cracking and water leakage.
- Do not allow children under 3 years old to have access to small parts during installation of this product.
- This installation must comply with all applicable state and local regulations.
- Turn off the water supply while replacing the filter.

Installation of the filter system

Step 1: Fix the filter head and the filter

1. Paste the assistant label to finish drilling. (Note: Mount the water filter at least 2 inches higher than the ground for easier filter change.)
2. Install the screw and reserve enough space to hang the filter.
3. Hang the filter system on the screw.

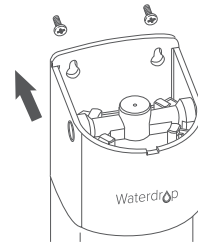

Step 2: Connect the water supply (cold water only)

1. Connect the inlet hose and the outlet hose to the filter head. (Figure 1)

Note: When the hose is tightly inserted, there will be a 1/8 inch gap between the hose and the filter head, which is designed for easy replacement and won't affect the sealing performance.

2. Shut off the water supply. Remove the faucet hose. (Figure 2)

Figure 1

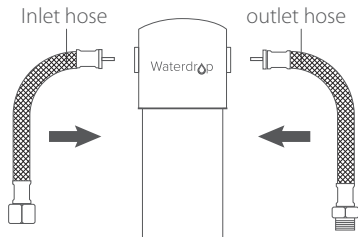
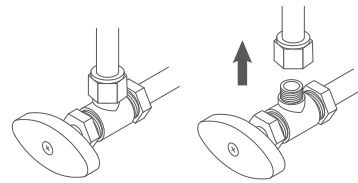

Figure 2



3. Connect the inlet hose to the cold water valve.

- If the angle valve outlet is 3/8", it can be directly connected to the water supply. (Figure 3)
- If the angle valve outlet is 1/2", connect it with a No.1 converter at first. (Figure 4)

Figure 3

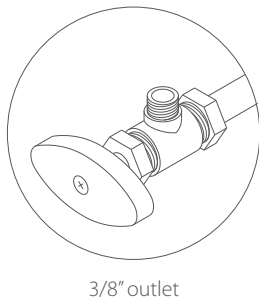
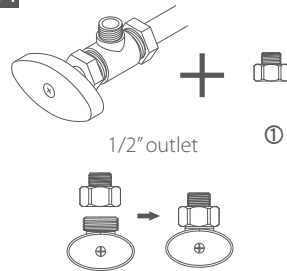

Figure 4



Connect ① to the cold angle valve

Step 3: Connect to the faucet

1. If the faucet hose is 3/8", it can be directly connected to the outlet hose. (Figure 5)
2. If the faucet hose is 1/2", connect it with a No.2 converter at first. (Figure 6)

Figure 5

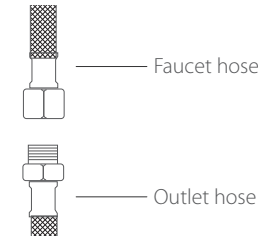
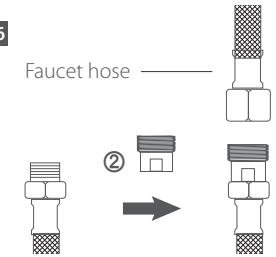

Figure 6



Note: If a female threaded connector is needed, please contact our service team for help.

Check the leaks and flush the filter

1. If water leakage occurs, turn off the water supply. If the water leakage is occurring at position 1 and 2, wrap Teflon tape on the external thread. If the water leakage is occurring at position 3 or 4, insert the quick-connect fitting to the end and make sure the hoses hit the bottom of the fitting.
2. Flush the filter for 5 minutes before use.

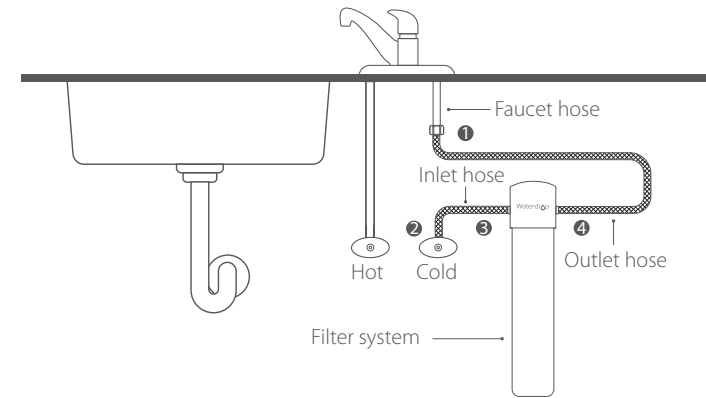

To disconnect

Use your thumb and index finger to press down on the lock sleeve. Use your other hand to pull out the hose from the fitting.

Note: Please do not pull out the tubing directly, or else it will damage the fitting and cause leakage.

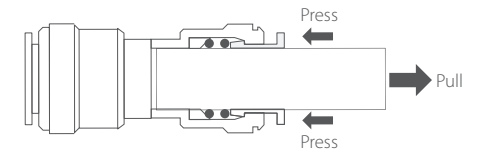

Filter replacement

1. It's recommended to turn off the water supply and turn on the faucet to release the water pressure.
2. Rotate 1/4 turn to the left to remove the filter.
3. Take out the new filter and remove the protective cap.
4. Rotate 1/4 turn to the right to install the filter. Ensure that the filter's triangle mark is aligned with the connection mark.
5. Turn on the cold water valve and flush for 5 minutes.

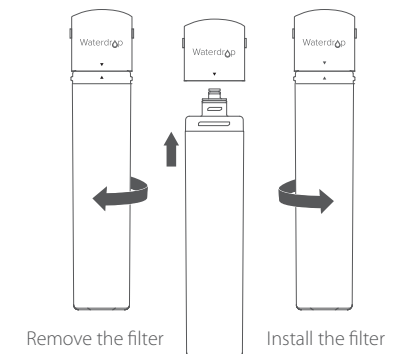

Frequently asked questions

Q: What should I do if water leaks after installation?

A: In the event of water leakage, turn off the water supply. If the water leakage is occurring at the thread, wrap Teflon tape on the external thread. If the water leakage is occurring at the quick connection position, insert the quick-connect fitting to the end and make sure the hoses hit the bottom of the fitting. Contact us for solutions if the water leakage persists.

Q: Why doesn't the TDS value lower after filtration?

A: The main purpose of this waterdrop filter is not to remove TDS. TDS stands for total dissolved solids, and it is basically composed of inorganic salts and a small amount of organic matter. The filter can remove harmful substances while keeping beneficial trace elements. Please choose Waterdrop RO system if you are looking for physical removal of TDS.

Q: When should I replace the filter?

A: The filter's service life is related to water quality. If the flow rate is significantly reduced or if the water has a peculiar smell, we suggest that you replace the filter. The recommended service life of the filter is as follows: 1 year for WD-RF10-UF, WD-RF10-MZ, 2 years for WD-RF15-UF, WD-RF15-MZ, 3 years for WD-RF17-UF, WD-RF17-MZ.

Q: Why does black water come out during flushing?

A: It's normal that black water comes out when flushing. The purpose is to remove carbon powder remaining on the surface of filter materials. You can normally use it after flushing for 5 minutes.

1 -year quality assurance

All mechanical devices with moving parts have a normal life span and will need to be replaced periodically. For this reason, mechanical devices such as water fittings, filter head, and faucets have a limited replacement assurance of 1 year. No assurance is given as to the service life of any filter cartridge, as the service life will vary based on local water conditions and water consumption.

If the product proves to be defective within 1 year from the date of purchase, please contact our customer service department. During the assurance period, we will replace or repair any part that is deemed to be defective if the product has not been subjected to tampering, alteration, or improper use after delivery, and has not been repaired by the manufacturer.

We do not make any promises in the event of misuse, use in abnormal temperature conditions, conditions outside those listed in the operating parameters, or use in commercial operations.

If you have problems during the purchase or installation process, please contact our customer service.

 **WARNING** Please read it carefully before installation.

The system and installation shall comply with applicable state and local regulations.

Waterdrop

Manufacturer Technical Support

Tel: 1-888-352-3558 (U.S.)

E-mail: service@waterdropfilter.com



Made in China V001
Qingdao Ecopure Filter Co., Ltd.

Installazione del sistema di filtrazione

Passaggio 1: Fissare la testa del filtro e il filtro.

1. Incollare l'etichetta guida per terminare la perforazione.
(Nota: montare il filtro dell'acqua almeno 5 cm più in alto rispetto al suolo per facilitare la sostituzione del filtro.)
2. Installare le viti e riservare spazio sufficiente per agganciare il filtro.
3. Appendere il sistema di filtraggio alle viti.

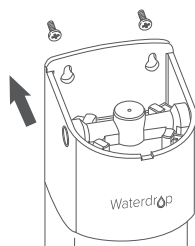

Passaggio 2: Collegare l'alimentazione idrica (solo acqua fredda)

1. Collegare il tubo di ingresso e il tubo di uscita alla testata del filtro. (Figura 1)
- Nota:** quando il tubo è inserito saldamente, ci sarà uno spazio di 1/8 di pollice tra il tubo e la testa del filtro, progettato per una facile sostituzione e non influirà sulle prestazioni di tenuta.
2. Chiudere l'alimentazione dell'acqua. Rimuovere il tubo flessibile del rubinetto. (Figura 2)

Figura 1



Figura 2



3. Collegare il tubo di alimentazione alla valvola dell'acqua fredda.
 - Se lo scarico della valvola angolata è di 3/8", può essere collegata direttamente alla rete idrica. (Figura 3)
 - Se lo scarico della valvola angolata è di 1/2", collegare con un a No.1 collegarla inizialmente con un convertitore n. 1. (Figura 4)

Figura 3

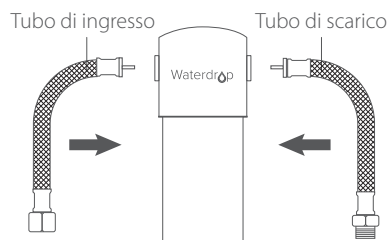
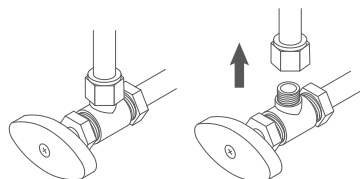
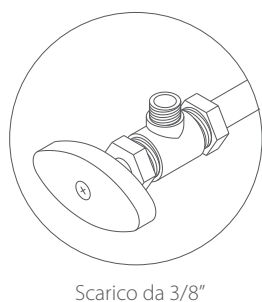

Scarico da 3/8"

Figura 4

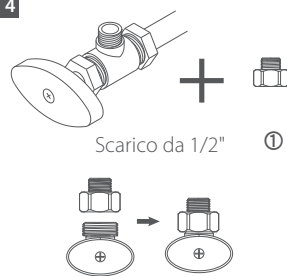

Collegare ① alla valvola ad angolo freddo

Passaggio 3: Collegati al rubinetto

1. Se il tubo del rubinetto è da 3/8", può essere collegato direttamente al tubo di uscita. (Figura 5)
2. Se il tubo del rubinetto è da 1/2", collegarlo inizialmente con un convertitore n. 2. (Figura 6)

Figura 5



Figura 6



Nota: se è necessario un connettore filettato femmina, contattare il nostro team di assistenza per assistenza.

Controllare le perdite e lavare il filtro

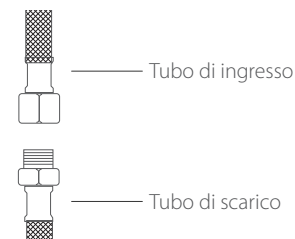
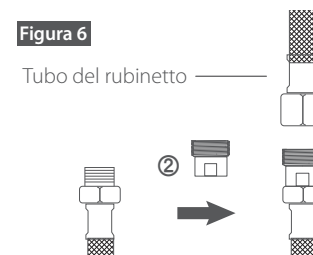
1. In caso di perdite d'acqua, chiudere l'alimentazione dell'acqua. Se la perdita d'acqua si verifica nelle posizioni 1 e 2, avvolgere il nastro di teflon sulla filettatura esterna. Se la perdita d'acqua si verifica in posizione 3 o 4, inserire il raccordo a connessione rapida fino all'estremità e assicurarsi che i tubi tocchino la parte inferiore del raccordo.

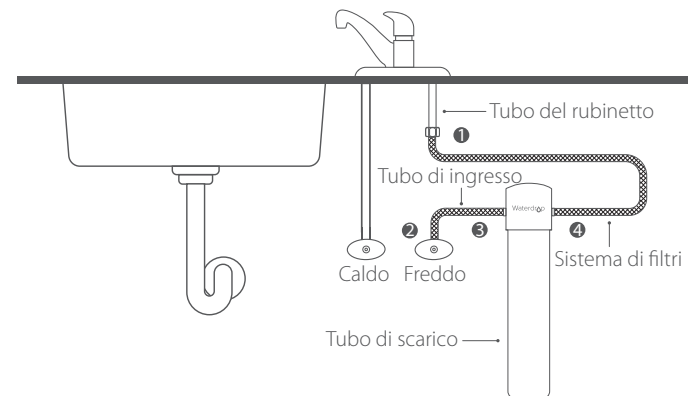

Per scollegare

- Usa il pollice e l'indice per premere sulla ghiera di blocco. Usa l'altra mano per estrarre il tubo dal raccordo.
- Nota:** non estrarre direttamente il tubo, altrimenti danneggerebbe il raccordo e causerebbe perdite.

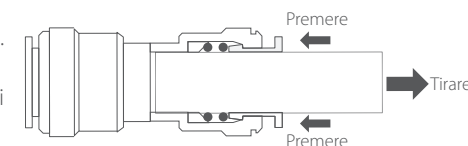

Sostituzione del filtro

1. Si consiglia di chiudere l'alimentazione idrica e aprire il rubinetto per rilasciare la pressione dell'acqua.
2. Ruotare di 1/4 di giro a sinistra per rimuovere il filtro.
3. Estrarre il nuovo filtro e rimuovere il cappuccio protettivo.
4. Ruotare di 1/4 di giro verso destra per installare il filtro. Assicurarsi che il contrassegno triangolare del filtro sia allineato con il contrassegno della connessione.
5. Aprire la valvola dell'acqua fredda e sciacquare per 5 minuti.

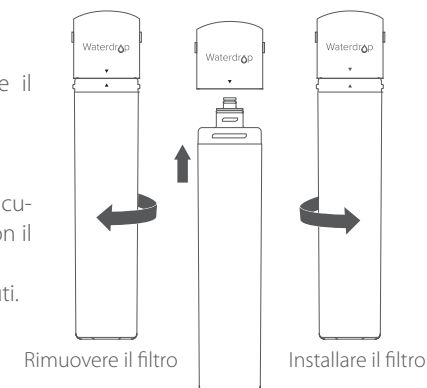

Installation du système de filtration

Étape 1 : Fixez la tête de filtre et le filtre.

1. Collez l'étiquette de l'assistant pour terminer le perçage.
(Remarque : Montez le filtre à eau au moins 2 pouces plus haut que le sol pour faciliter le changement de filtre).
2. Installez la vis et réservez un espace suffisant pour suspendre le filtre.
3. Accrochez le filtre sur la vis.

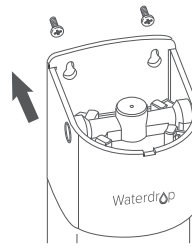

Étape 2 : Raccorder l'alimentation en eau (eau froide uniquement)

1. Connectez le tuyau d'entrée et le tuyau de sortie à la tête du filtre. (Figure 1)

Remarque : Lorsque le tuyau est bien inséré, il y aura un espace de 1/8 pouce entre le tuyau et la tête du filtre,

ce qui est conçu pour un remplacement facile et n'affectera pas les performances d'étanchéité.

2. Fermez l'alimentation en eau. Retirez le tuyau du robinet. (Figure 2)

Figure 1

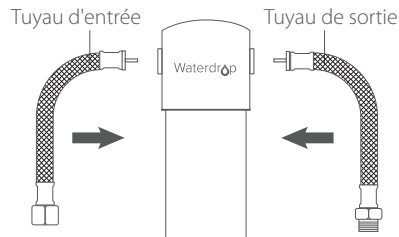
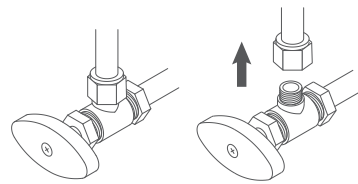

Figure 2



3. Raccordez le tuyau d'entrée à la vanne d'eau froide.

- Si la sortie de la vanne d'angle est de 3/8", elle peut être directement raccordée à l'alimentation en eau. (Figure 3)

- Si la sortie de la vanne d'angle est de 1/2", connectez-la d'abord avec un convertisseur No.1. (Figure 4)

Figure 3

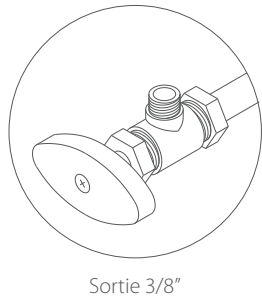

Sortie 3/8"

Figure 4

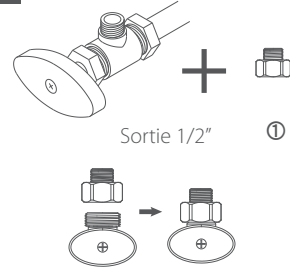

Sortie 1/2"

Connecter ① à la valve d'angle froide

Étape 3 : Raccordement au robinet

1. Si le tuyau du robinet est de 3/8", il peut être directement connecté au tuyau de sortie. (Figure 5)
2. Si le tuyau du robinet est de 1/2", raccordez-le d'abord avec un convertisseur No.2. (Figure 6)

Figure 5

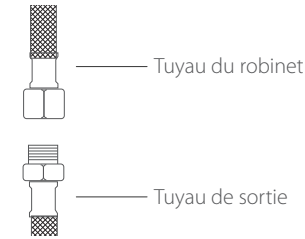
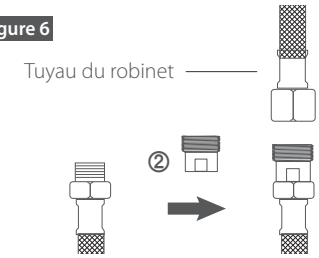

Figure 6



Remarque : si un connecteur à filetage femelle est nécessaire, veuillez contacter notre équipe de service pour obtenir de l'aide.

Vérifier les fuites et rincer le filtre

1. Si une fuite d'eau se produit, coupez l'alimentation en eau. Si la fuite d'eau se produit aux positions 1 et 2, enroulez du ruban téflon sur le filetage extérieur. Si la fuite d'eau se produit à la position 3 ou 4, insérez le raccord rapide à l'extrémité et assurez-vous que les tuyaux touchent le dessous du raccord.
2. Rincez le filtre pendant 5 minutes avant de l'utiliser.

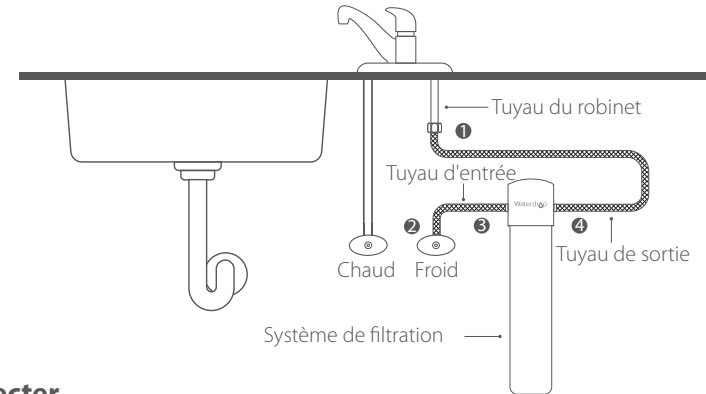

Pour déconnecter

Utilisez votre pouce et votre index pour appuyer sur le manchon de verrouillage. Utilisez votre autre main pour retirer le tuyau du raccord.

Remarque : Ne tirez pas directement sur le tuyau, sinon vous risquez d'endommager le raccord et de provoquer des fuites.

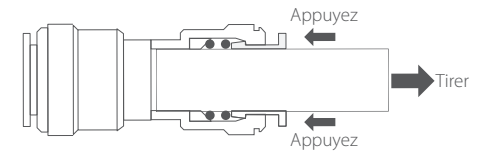

Remplacement du filtre

1. Il est recommandé de couper l'alimentation en eau et d'ouvrir le robinet pour relâcher la pression de l'eau.
2. Tournez d'1/4 de tour vers la gauche pour retirer le filtre.
3. Sortez le nouveau filtre et retirez le capuchon de protection.
4. Tournez 1/4 de tour vers la droite pour installer le filtre. Veillez à ce que le repère triangulaire du filtre soit aligné avec le repère de connexion.
5. Ouvrez la vanne d'eau froide et rincez pendant 5 minutes.

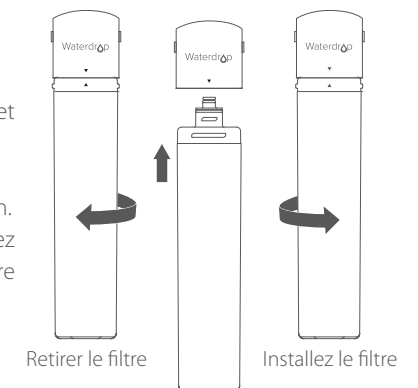

Instalación del sistema de filtrado

Paso 1: Fijar el cabezal del filtro y el filtro.

1. Pegue la etiqueta auxiliar para terminar de taladrar.
(Nota: Instale el filtro de agua al menos 5 cm más alto que el suelo para facilitar el cambio de filtro).
2. Instale el tornillo y reserve espacio suficiente para colgar el filtro.
3. Cuelgue el filtro en el tornillo.

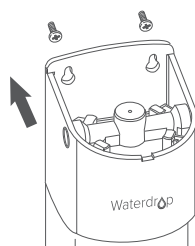

Paso 2: Conectar el suministro de agua (sólo agua fría)

1. Conecte la manguera de entrada y la manguera de salida al cabezal del filtro. (Figura 1)
- Nota:** Cuando la manguera está bien insertada, habrá un espacio de 1/8 de pulgada entre la manguera y el cabezal del filtro, que está diseñado para facilitar el reemplazo y no afectará el rendimiento de sellado.
2. Cierre el suministro de agua. Retire la manguera del grifo. (Figura 2)

Figura 1



Figura 2



3. Conecte la manguera de entrada a la válvula de agua fría.
 - Si la salida de la válvula angular es de 3/8", puede conectarse directamente al suministro de agua. (Figura 3)
 - Si la salida de la válvula de ángulo es de 1/2", conéctela primero con un convertidor n.º 1. (Figura 4)

Figura 3

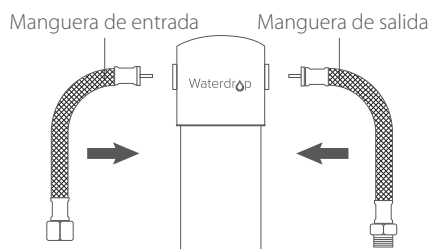
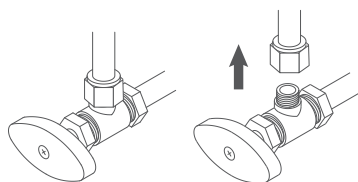
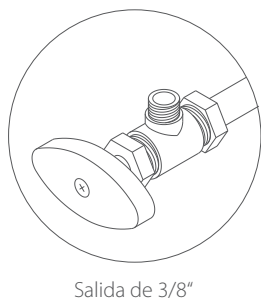

Salida de 3/8"

Figura 4

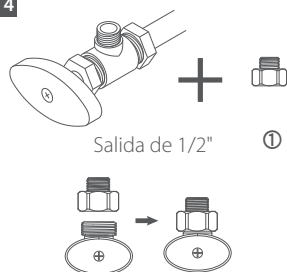

Conectar ① a la válvula de ángulo frío.

Paso 3: Conectar al grifo

1. Si la manguera del grifo es de 3/8", se puede conectar directamente a la manguera de salida. (Figura 5)
2. Si la manguera del grifo es de 1/2", conéctela primero con un convertidor n.º 2. (Figura 6)

Figura 5



Figura 6



Nota: Si necesita un conector de rosca hembra, póngase en contacto con nuestro equipo de servicio técnico para obtener ayuda.

Comprobar las fugas y enjuagar el filtro

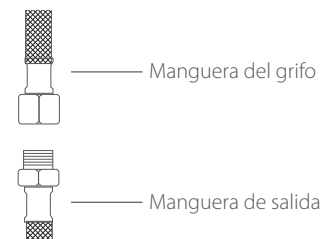
1. Si se produce una fuga de agua, cierre el suministro de agua. Si la fuga de agua se produce en las posiciones 1 y 2, coloque cinta de teflón en la rosca exterior. Si la fuga de agua se produce en la posición 3 o 4, inserte el accesorio de conexión rápida hasta el final y asegúrese de que las mangueras tocan la parte inferior del accesorio.
2. Enjuague el filtro durante 5 minutos antes de utilizarlo.

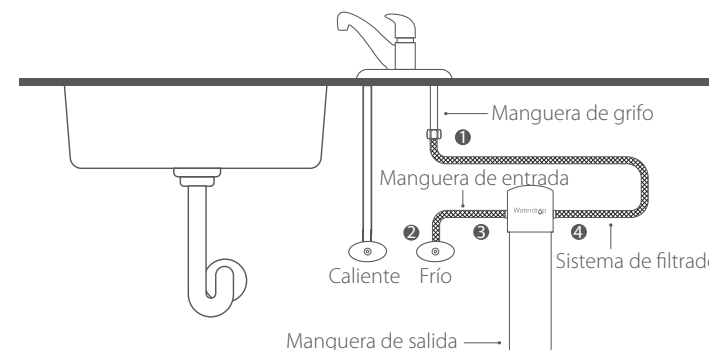

Para desconectar

Presione el casquillo de cierre con los dedos pulgar e índice. Utilice la otra mano para extraer la manguera del racor.

Nota: No tire de la manguera directamente, de lo contrario dañará el accesorio y provocará fugas.

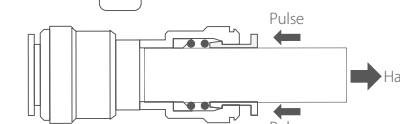

Sustitución del filtro

1. Se recomienda cerrar el suministro de agua y abrir el grifo para liberar la presión del agua.
2. Gire 1/4 de vuelta hacia la izquierda para retirar el filtro.
3. Saque el filtro nuevo y retire la tapa protectora.
4. Gire 1/4 de vuelta hacia la derecha para instalar el filtro. Asegúrese de que la marca triangular del filtro está alineada con la marca de conexión.
5. Abra la válvula de agua fría y enjuague durante 5 minutos.

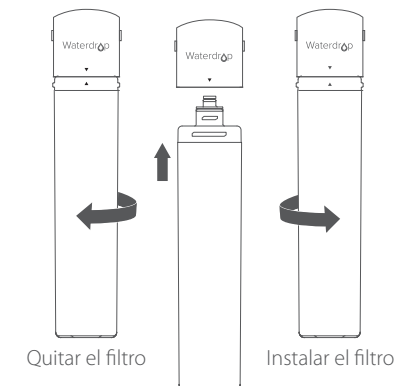

Einbau des Filtersystems

Schritt 1: Befestigen Sie den Filterkopf und den Filter.

1. Fügen Sie das Assistentetikett ein, um die Bohrung zu beenden.
(Hinweis: Montieren Sie den Wasserfilter mindestens 5 cm höher als den Boden, um den Filterwechsel zu erleichtern).
2. Bringen Sie die Schraube an und reservieren Sie genügend Platz zum Aufhängen des Filters.
3. Hängen Sie den Filter syst an die Schraube.

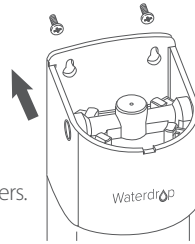

Schritt 2: Anschließen der Wasserversorgung (nur Kaltwasser)

1. Verbinden Sie den Einlassschlauch und den Auslassschlauch mit dem Filterkopf. (Abbildung 1)

Hinweis: Wenn der Schlauch fest eingesteckt ist, verbleibt ein Spalt von 1/8 Zoll zwischen dem Schlauch und dem Filterkopf, der für einen einfachen Austausch vorgesehen ist und die Dichtungsleistung nicht beeinträchtigt.

2. Stellen Sie die Wasserzufuhr ab. Entfernen Sie den Schlauch des Wasserhahns. (Abbildung 2)

Abbildung 1



Abbildung 2



3. Schließen Sie den Zulaufschlauch an das Kaltwasserventil an.

• Wenn der Eckventilausgang 3/8" ist, kann er direkt an die Wasserversorgung angeschlossen werden.

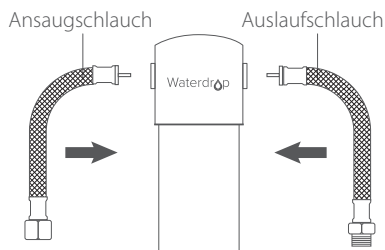
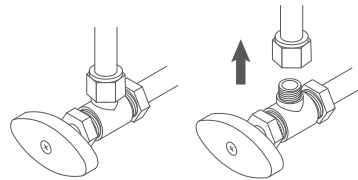
(Abbildung 3)

• Wenn der Auslass des Eckventils 1/2" ist, verbinden Sie ihn zunächst mit einem Konverter Nr. 1. (Abbildung 4)

Abbildung 3



Abbildung 4



Schritt 3: Anschluss an den Wasserhahn

1. Wenn der Schlauch des Wasserhahns 3/8" ist, kann er direkt an den Auslassschlauch angeschlossen werden. (Abbildung 5)
2. Wenn der Schlauch des Wasserhahns 1/2" ist, schließen Sie ihn zunächst mit einem Konverter Nr. 2 an. (Abbildung 6)

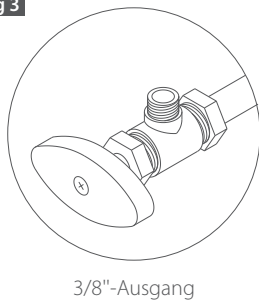
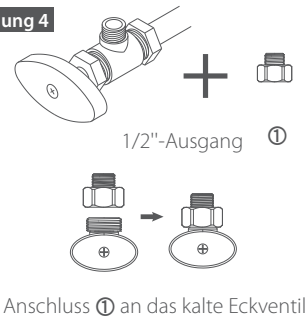
Abbildung 5



Abbildung 6



Hinweis: Wenn Sie einen Anschluss mit Innengewinde benötigen, wenden Sie sich bitte an unser Serviceteam, um Hilfe zu erhalten.

Prüfen Sie die Dichtheit und spülen Sie den Filter

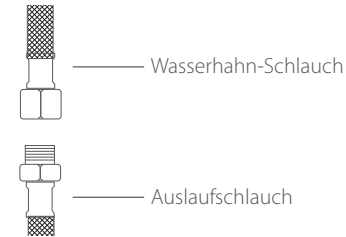
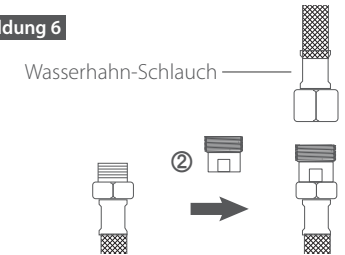
1. Wenn Wasser austritt, stellen Sie die Wasserzufuhr ab. Wenn das Wasser an den Positionen 1 und 2 austritt, wickeln Sie Teflonband um das Außengewinde. Tritt das Wasser an Position 3 oder 4 aus, stecken Sie das Schnellanschlusstück an das Ende und stellen Sie sicher, dass die Schläuche den Boden des Anschlusstücks berühren.

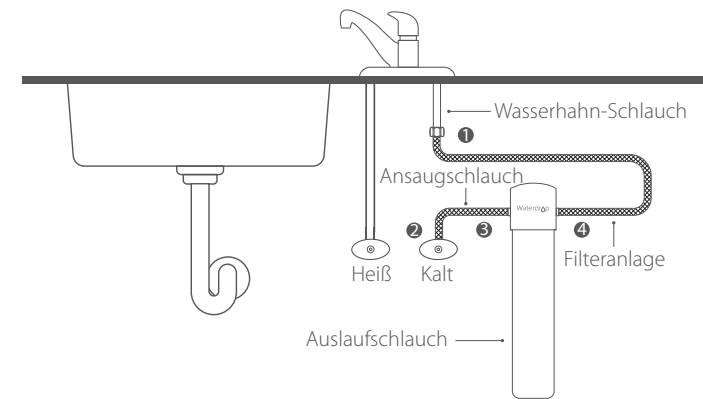

Zum Trennen der Verbindung

Drücken Sie mit Daumen und Zeigefinger auf die Verschlusshülse. Ziehen Sie mit der anderen Hand den Schlauch aus der Verschraubung.

Hinweis: Bitte ziehen Sie den Schlauch nicht direkt heraus, da sonst die Verschraubung beschädigt wird und es zu Undichtigkeiten kommt.

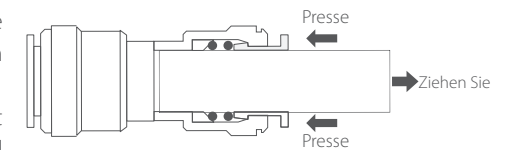

Austausch des Filters

1. Es wird empfohlen, die Wasserversorgung abzustellen und den Wasserhahn aufzudrehen, um den Wasserdruck abzulassen.
2. Drehen Sie den Filter um 1/4 Umdrehung nach links, um ihn zu entfernen.
3. Nehmen Sie den neuen Filter heraus und entfernen Sie die Schutzkappe.
4. Drehen Sie den Filter um 1/4 Umdrehung nach rechts, um ihn zu installieren. Stellen Sie sicher, dass die Dreiecksmarkierung des Filters auf die Anschlussmarkierung ausgerichtet ist.
5. Drehen Sie das Kaltwasserventil auf und spülen Sie 5 Minuten lang.

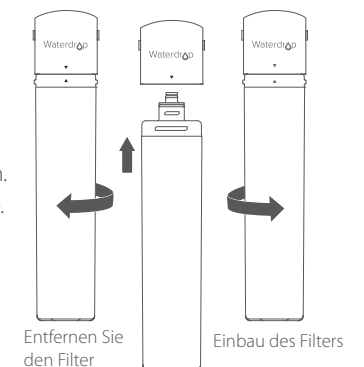

Montaż systemu filtracyjnego

Krok 1: Mocowanie głowicy i filtra

1. Naklej etykietę pomocniczą, aby zakończyć wiercenie. (Uwaga: Zamontuj filtr wody co najmniej 2 cale powyżej podłoża, aby ułatwić jego wymianę).
2. Zamontuj śrubę i zastaw wystarczająco dużo miejsca, aby zawiesić filtr
3. Zawieś system filtrów na śrubie.

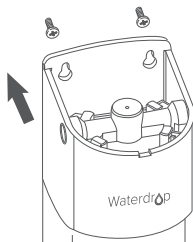

Krok 2: Podłączenie dopływu wody (tylko zimna woda)

1. Podłącz wężyk wlotowy i wężyk wylotowy do głowicy filtra. (Rysunek 1)

Uwaga: Po szczelnym założeniu wężyka, pomiędzy wężykiem a głowicą filtra pozostanie szczelina 1/8 cala, która ma na celu łatwą wymianę i nie wpłynie na szczelność.

2. Odetnij dopływ wody. Zdejmij wężyk z kranu. (Rysunek 2)

Rysunek 1

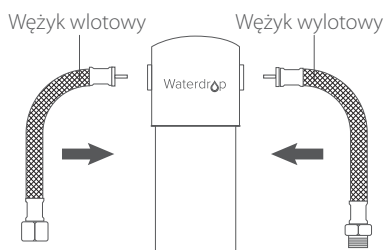

Rysunek 2

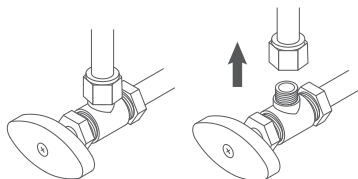

3. Podłącz wężyk wlotowy do zaworu zimnej wody.

- Jeśli wylot zaworu kątownego ma rozmiar 3/8", można go podłączyć bezpośrednio do źródła wody. (Rysunek 3)
- Jeśli wylot zaworu kątownego ma rozmiar 1/2", podłącz najpierw przejściówkę nr 1. (Rysunek 4)

Rysunek 3

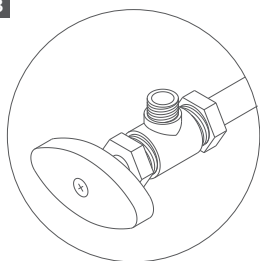

Wylot 3/8"

Rysunek 4

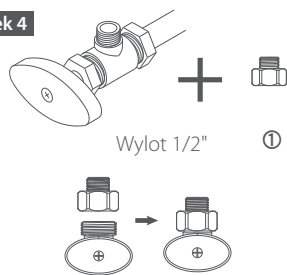

Podłącz ① do zaworu kątownego zimnego

Krok 3: Podłącz do kranu

1. Jeśli wężyk kranu ma średnicę 3/8", można go bezpośrednio podłączyć do wężyka wylotowego. (Rysunek 5)
2. Jeśli wężyk kranu ma średnicę 1/2", najpierw należy go podłączyć za pomocą konwertera nr 2. (Rysunek 6)

Rysunek 5

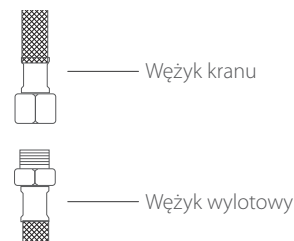

Rysunek 6

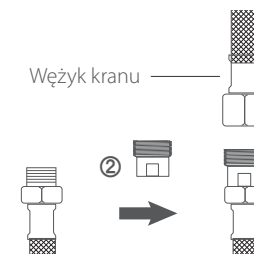

Uwaga: Jeżeli konieczne jest zastosowanie złącza z gwintem żeńskim, prosimy o kontakt z naszym działem obsługi w celu uzyskania pomocy.

Kontrola szczelności i płukanie filtra

1. Jeżeli wystąpi wyciek wody, należy wyłączyć jej dopływ. Jeśli wyciek wody występuje w pozycji 1 i 2, nawiń taśmę teflonową na gwint zewnętrzny. Jeśli wyciek wody występuje w pozycji 3 lub 4, wsuń szybkozłączkę do końca i sprawdź, czy węże sięgają końca złączki.
2. Przed użyciem przepłucz filtr przez 5 minut.

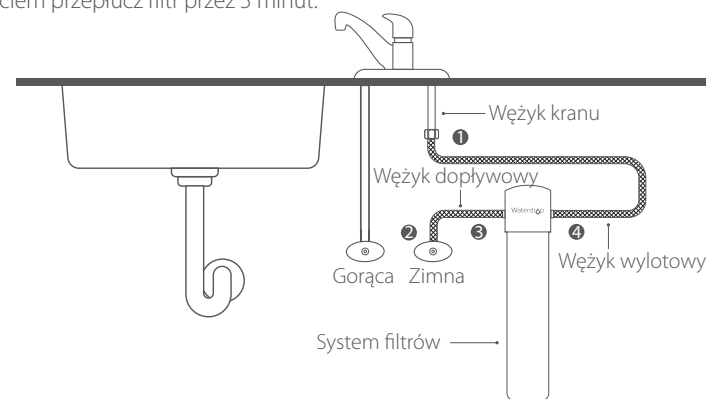

Aby rozłączyć

Użyj kciuka i palca wskazującego, aby nacisnąć tuleję blokującą. Użyj drugiej ręki, aby wyciągnąć wężyk ze złączki.

Uwaga: Nie wyciągaj rurki bezpośrednio, gdyż w ten sposób uszkodzisz złączkę i spowodujesz wyciek.

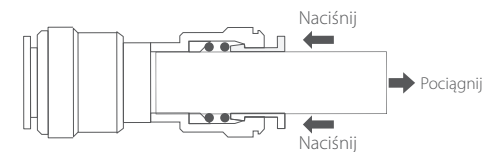

Wymiana filtra

1. Wskazane jest zakręcenie dopływu wody i odkręcenie kranu w celu zwolnienia ciśnienia.
2. Aby wyjąć filtr, należy obrócić go o 1/4 obrotu w lewo.
3. Wyjmij nowy filtr i zdejmij nasadkę ochronną.
4. Aby zamontować filtr, obróć go o 1/4 obrotu w prawo. Upewnij się, że znak trójkąta filtra jest wyrównany ze znakiem połączenia.
5. Odkręć zawór zimnej wody i płucz przez 5 minut.

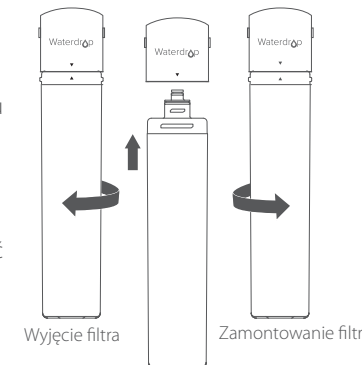

Installatie van het filtersysteem

Stap 1: Bevestig de filterkop en het filter

1. Plak het assistentielabel om het boren af te maken. (Opmerking: Monteer het waterfilter ten minste 2 centimeter hoger dan de grond om het filter gemakkelijker te kunnen verwisselen).

2. Installeer de schroef en reserveer voldoende ruimte om het filter op te hangen.

3. Hang het filtersysteem aan de schroef.

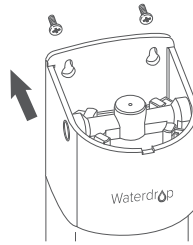

Stap 2: Sluit de watertoevoer aan (alleen koud water)

1. Sluit de inlaatslang en de uitlaatslang aan op de filterkop. (Figuur 1)

Opmerking: Als de slang goed vastzit, is er een ruimte van ¼ cm tussen de slang en de filterkop, die bedoeld is om gemakkelijk te vervangen en de afdichtende werking niet beïnvloedt.

2. Sluit de watertoevoer af. Verwijder de kraanslang. (Figuur 2)

Figuur 1

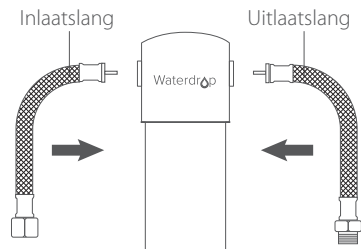

Figuur 2

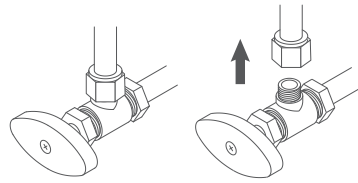

3. Sluit de inlaatslang aan op de koudwaterkraan.

• Als de uitlaat van de hoekklep 3/8" is, kan hij rechtstreeks op de watertoevoer worden aangesloten. (Figuur 3)

• Als de uitlaat van de hoekklep 1/2" is, sluit hem dan eerst aan met een No.1 converter. (Figuur 4)

Figuur 3

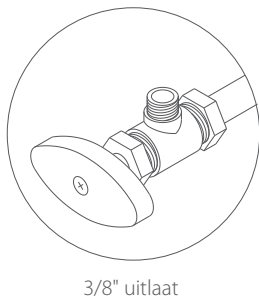

3/8" uitlaat

Figuur 4

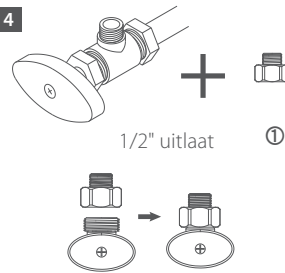

Sluit ① aan op de koude hoekklep

Stap 3: Verbind met de kraan

1. Als de kraanslang 3/8" is, kan deze direct worden aangesloten op de uitlaatslang. (Figuur 5)

2. Als de kraanslang 1/2" is, verbind deze dan eerst met een No.2 converter. (Figuur 6)

Figuur 5

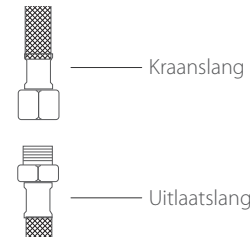

Figuur 6

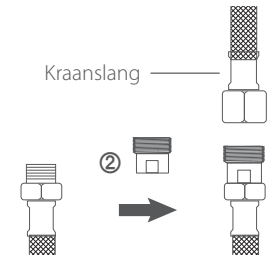

Opmerking: Als een connector met binnendraad nodig is, neem dan contact op met ons serviceteam voor hulp.

Controleer de lekken en spoel het filter door

1. Schakel de watertoevoer uit als er waterlekage optreedt. Als de waterlekage optreedt op positie 1 en 2, wikkel dan teflon tape op de buitendraad. Als het water lekt op positie 3 of 4, steek dan de snelkoppeling op het uiteinde en zorg ervoor dat de slangen de bodem van de fitting raken.

2. Spoel het filter 5 minuten voor gebruik.

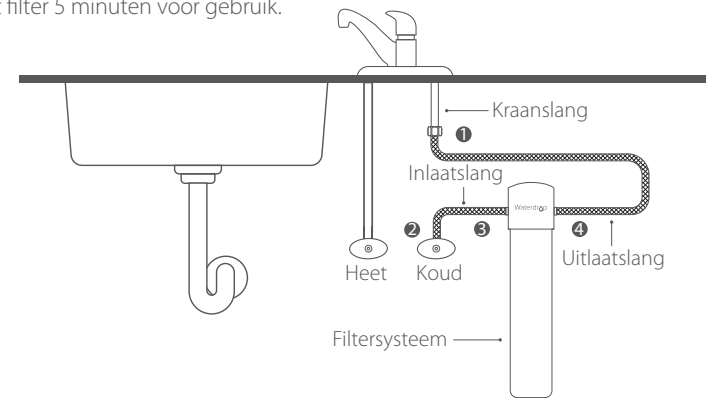

Loskoppelen

Gebruik je duim en wijsvinger om de lock sleeve naar beneden te drukken. Gebruik je andere hand om de slang uit de fitting te trekken.

Opmerking: Trek de slang er niet rechtstreeks uit, anders beschadigt de fitting en ontstaat er lekkage.

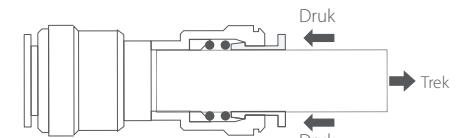

Vervanging van het filter

1. We raden aan om de watertoevoer af te sluiten en de kraan open te draaien om de waterdruk te laten ontsnappen.

2. Draai 1/4 slag naar links om het filter te verwijderen.

3. Haal het nieuwe filter eruit en verwijder de beschermkap.

4. Draai 1/4 slag naar rechts om het filter te installeren. Zorg ervoor dat de driehoeksmarkering van het filter is uitgelijnd met de aansluitmarkering.

5. Draai de koudwaterkraan open en spoel 5 minuten door.

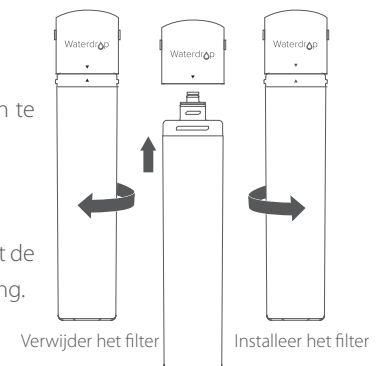

Verwijder het filter

Installeer het filter

Installation av filtersystemet

Steg 1: Fixa filterhuvudet och filtret

1. Klistra in assistentetiketten för att avsluta borringen. (Obs: Montera vattenfiltret minst 5 cm högre än marken för enklare filterbyte.)
2. Installera skruven och reservera tillräckligt med utrymme för att hänga filtret.
3. Häng filtersystemet på skruven.

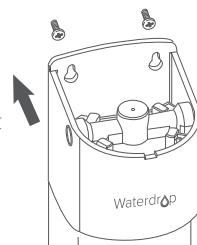

Steg 2: Anslut vattentillförseln (endast kallt vatten)

1. Anslut inloppsslangen och utloppsslangen till filterhuvudet. (Bild 1)

Obs: När slangen är ordentligt isatt kommer det att finnas ett mellanrum på 0,3 cm mellan slangen och filterhuvudet, vilket är utformat för enkelt byte och påverkar inte tätningsprestandan.

2. Stäng av vattentillförseln. Ta bort kranslangen. (Bild 2)

Bild 1



Bild 2



3. Anslut inloppsslangen till kallvattenventilen.

- Om vinkelventilutloppet är 3/8" kan det anslutas direkt till vattenförsörjningen. (Bild 3)
- Om vinkelventilutloppet är 1/2", anslut det först med en Nr.1-omvandlare. (Bild 4)

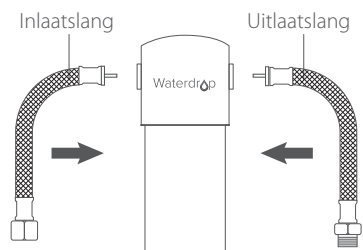
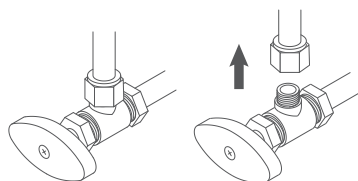
Bild 3

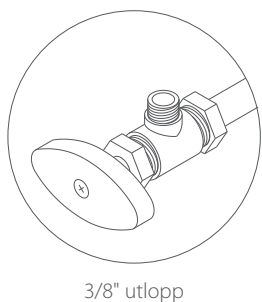

3/8" utlopp

Bild 4

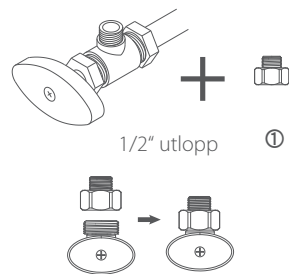

1/2" utlopp

Anslut ① till kallvinkelventilen

Steg 3: Anslut till kranen

1. Om kranens slang är 3/8" kan den direkt anslutas till utloppsslangen. (Bild 5)
2. Om kranens slang är 1/2", anslut den först med en Nr.2-omvandlare. (Bild 6)

Bild 5



Bild 6



Obs: Om en gängad honkontakt behövs, vänligen kontakta vårt serviceteam för hjälp.

Kontrollera läckorna och spola filtret

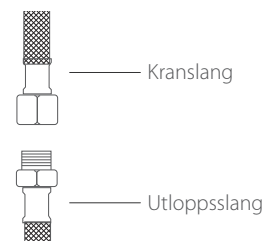
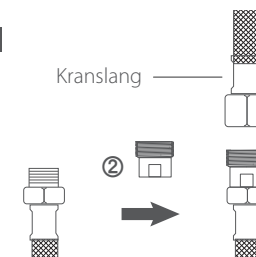
1. Om vattenläckage uppstår, stäng av vattentillförseln. Om vattenläckaget inträffar vid position 1 och 2, linda teflontejp på utvändig gänga. Om vattenläckaget inträffar i läge 3 eller 4, sätt in snabbkopplingen i änden och se till att slangarna träffar botten av kopplingen.
2. Spola filtret i 5 minuter före användning.

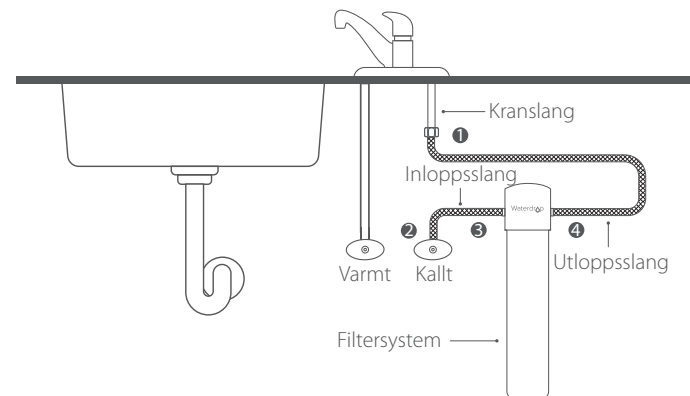

Så här kopplar du från

Använd tummen och pekfingret för att trycka ner låshylsan. Använd din andra hand för att dra ut slangen från kopplingen.

Obs: Dra inte ut slangen direkt, annars kommer det att skada kopplingen och orsaka läckage.

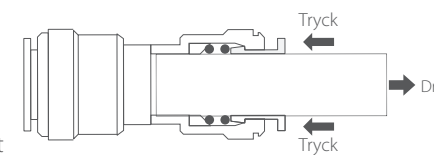

Byte av filter

1. Det rekommenderas att stänga av vattentillförseln och slå på kranen för att släppa vattentrycket.
2. Roter 1/4 varv åt vänster för att ta bort filtret.
3. Ta ut det nya filtret och ta bort skyddskåpan.
4. Vrid 1/4 varv åt höger för att installera filtret. Kontrollera att filtrets triangelmärkning är justerad mot kopplingsmärket.
5. Slå på kallvattenventilen och spola i 5 minuter.

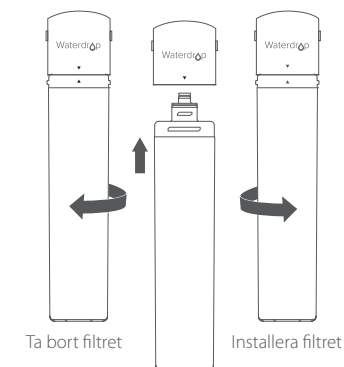

Filtre sisteminin kurulumu

1. Adım: Filtre kafasını ve filtreyi sabitleyin

1. Delme işlemini bitirmek için yardımcı etiketi yapıştırmın. (Not: Daha kolay filtre değişimi için su filtresini yerden en az 2 inç yükseğe monte edin).
2. Vidayı takın ve filtreyi asmak için yeterli alan ayırın.
3. H filtre sisteminin vidaya takın.

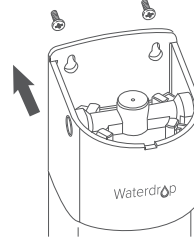

2. Adım: Su şebekesini bağlayın (sadece soğuk su)

1. Giriş hortumunu ve çıkış hortumunu filtre kafasına bağlayınız. (Şekil 1)

Not: Hortum sıkıca yerleştirildiğinde, hortum ile filtre başlığı arasında 3 mm boşluk kalır, bu boşluk kolay değiştirme için tasarlanmıştır ve sızdırmazlık performansını etkilemez.

2. Su şebekesini kapatın. Musluk hortumunu çıkarın. (Şekil 2)

Şekil 1

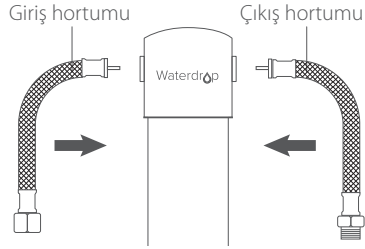

Şekil 2

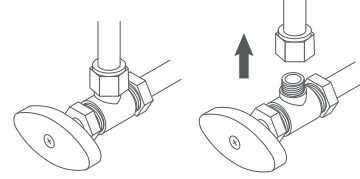

3. Giriş hortumunu soğuk su vanasına bağlayın.

- Açılı vana çıkışı 9mm ise, doğrudan su kaynağına bağlanabilir. (Şekil 3)
- Açılı vana çıkışı 125mm ise, önce 1 numaralı dönüştürücü ile bağlayın. (Şekil 4)

Şekil 3

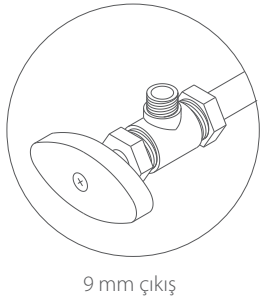

9 mm çıkış

Şekil 4

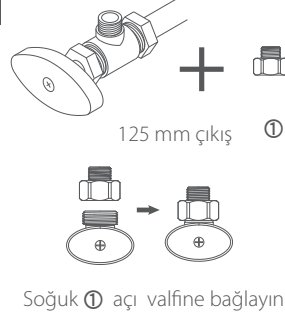

Soğuk ① açılı valfine bağlayın

3. Adım: Musluk ile bağlantı yapın

1. Eğer musluk hortumu 9mm ise, doğrudan çıkış hortumuna bağlanabilir. (Şekil 5)
2. Eğer musluk hortumu 125mm ise, önce bir No.2 dönüştürücü ile bağlayın. (Şekil 6)

Şekil 5

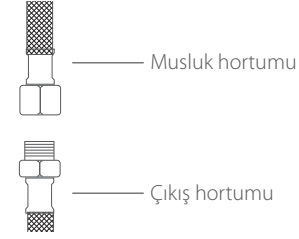

Şekil 6

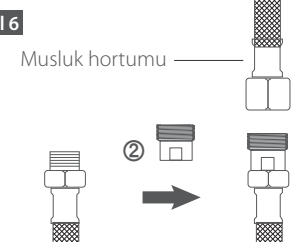

Not: Dişi vida bağlantılı bir konektör gerekiyorsa, yardım için lütfen servis ekibimize iletişime geçin.

Sızıntıları kontrol edin ve filtreyi yıkayın

1. Eğer su sızıntısı yaşanırsa su kaynağını mutlaka kapatın. Su sızıntısı 1. ve 2. konumda meydana geliyorsa dış taraftaki dişe Teflon bant sarın. Su sızıntısı 3. veya 4. konumda meydana geliyorsa, hızlı bağlantı parçasını uca takın ve hortumların parçanın altına denk gelmesini sağlayın.
2. Kullanmadan önce filtreyi 5 dakika boyunca temizleyin.

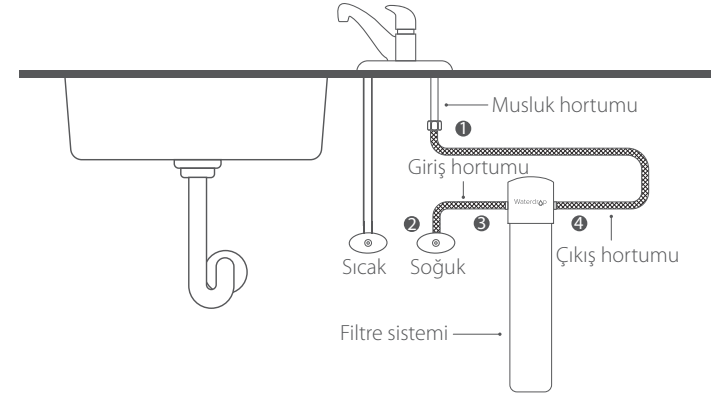

Bağlantıyı kesmek için

Kilit koluna bastırmak için başparmağınızı ve işaret parmağınızı kullanın. Hortumu bağlantı parçasından çıkarmak için diğer elinizi kullanın.

Not: Lütfen hortumu doğrudan dışarı çekmeyin, aksi takdirde bağlantı parçasına zarar verir ve sızıntıya neden olur.

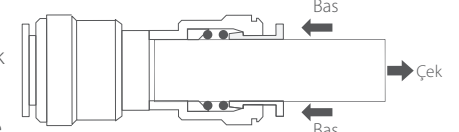

Filtre değişimi

1. Su şebekesinin kapatılması ve su basıncını boşaltmak için musluğun açılması tavsiye edilir.
2. Filtreyi çıkarmak için çeyrek tur sola döndürün.
3. Yeni filtreyi çıkarın ve koruyucu kapağı çıkarın.
4. Filtreyi takmak için çeyrek tur sağa döndürün. Filtrenin üçgen işaretinin bağlantı işaretiyle aynı hizada olduğundan emin olun.
5. Soğuk su vanasını açın ve 5 dakika boyunca temizleyin.

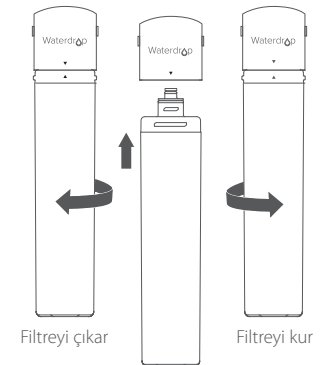

Filtreyi çıkar

Filtreyi kur